

PROPANE INSTALLATION AND OPERATION GUIDE FOR

EXOTIC FLAMES

Serving Commercial and Residential Clientele

Featuring FireGlass® Tempered, Processed, Formulated Glass ©2005 - 2016

CUSTOM PROPANE (LP) FIREPLACE BURNER INSTRUCTIONS

Adequate Fireplace Ventilation is Required

NOTE: READ INSTRUCTIONS FULLY BEFORE INSTALLING OR OPERATING.
INSTALLERS, LEAVE THESE INSTRUCTIONS WITH THE CONSUMER!

This product must be burned only in a fully vented, non-combustible fireplace with the damper completely open and the chimney free of any obstructions or restrictions. The fireplace must be designed and approved to burn wood. The minimum permanent, free opening in the fireplace chimney must be 8 inches in diameter (50 sq. inches) or greater.

IT IS THE HOMEOWNER'S RESPONSIBILITY TO ASSURE THAT THEIR FIREPLACE HAS ADEQUATE DRAFT.

WARNING: IF THE INFORMATION IN THIS MANUAL IS NOT FOLLOWED EXACTLY, A FIRE OR EXPLOSION MAY RESULT CAUSING PROPERTY DAMAGE, PERSONAL INJURY OR LOSS OF LIFE.

FOR YOUR SAFETY – IF YOU SMELL GAS

1. OPEN WINDOWS
2. DON'T TOUCH ELECTRICAL SWITCHES
3. EXTINGUISH ANY OPEN FLAMES
4. IMMEDIATELY CALL YOUR GAS SUPPLIER

FLAMMABLE VAPORS MAY BE DRAWN BY AIR CURRENTS FROM OTHER AREAS OF YOUR HOUSE TO THIS APPLIANCE.

GENERAL INFORMATION

DO NOT USE A NATURAL GAS BURNER FOR PROPANE OR A PROPANE BURNER FOR NATURAL GAS. WHEN USING PROPANE GAS (LP) AN AUTOMATIC PILOT SYSTEM MUST BE INSTALLED.

1. There are many different local codes for gas fireplaces. The installation of FireGlass glass must conform to your local codes, or in the absence of local codes, conform to the National Fuel Gas Code (ANSI Z223.1 1999).
2. When glass fireplace doors are used, always operate fireplace with the doors fully open to allow for proper combustion.
3. Periodically, the glass may be dusted with a soft feather duster. The top layer may also be scooped up and taken to a water source and washed.
4. **Do not burn wood with this product.**

NOTE: THIS PRODUCT MUST BE INSTALLED BY PERSONNEL QUALIFIED TO INSTALL GAS APPLIANCES, IF REQUIRED BY YOUR LOCAL CODES. EXOTIC FLAMES BEARS NO RESPONSIBILITY FOR YOUR ACTIONS.

Note: This installation manual is for a Custom Propane Fireplace Burner made in part, from UL approved components. The valve assembly along with the thermocouple/pilot assemblies, which are the most important components of the burner, shall always be UL approved components.

DAMPER STOP **(Optional)**

Attach the damper stop clamp to the fireplace damper blade. Position the clamp to prevent full closure of the fireplace damper blade. (Figure 1)

If the damper stop does not fit, the installer shall install a permanent damper stop that will keep the damper open a minimum of 3 inches.

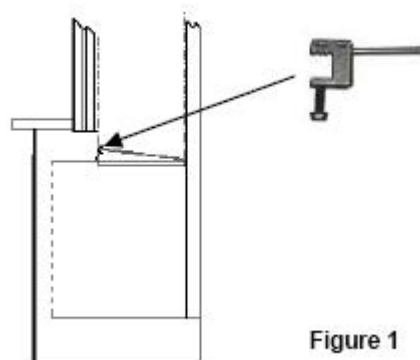

Step 1

Connect the flex line to the supply line where it enters your fireplace. Please use UL approved (gas rated) Teflon tape on all male threads to ensure a leak-free connection. Then position your burner as shown below. Your fireplace floor may be rectangular or vary from the image below, but the concept will still apply.

Top View of Fire Box with Burner Pan Assembly (controls may be on right or left side)

Use center burner pipe to center entire burner assembly to the (left-right) center point in your fireplace.

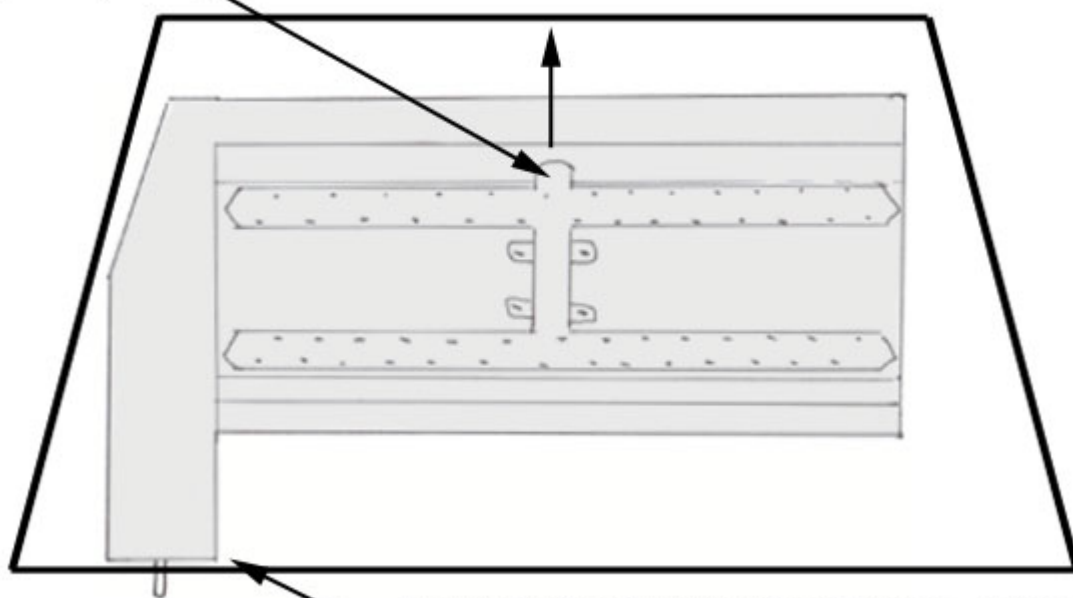

Bring valve tunnel to front edge of fire box. Make sure the front of this tunnel never gets obstructed.

! Very Important ! Now, open any gas inline shutoff valve to enable a gas supply to your burner. Wait several minutes to see if you smell any gas. You should not smell any gas at all. If you do, you must investigate and correct the leak before you can continue with the installation.

Step 2

Following the procedure below, briefly light the Pilot to make sure there is a supply of gas.

Position the Pilot/Thermocouple Assembly so it rests somewhere over the top of the burner pan.

[View of Control Valve](#)



With the knob pointing at the word "Pilot", fully depress the knob while holding a flame to the pilot. It may take several minutes for the gas to reach the pilot, so you can keep trying to light the pilot every few seconds. Once the pilot lights, keep the knob fully depressed for several more seconds until the flame remains burning once you let go of the knob. The flame must have continuous contact with the thermocouple in order for the pilot to stay lit after releasing the knob. Once the pilot stays lit on its own for 1 minute, partially depress the knob, turning the knob to the "Off" position to turn the pilot off.

[View of Pilot/Thermocouple Assembly](#)

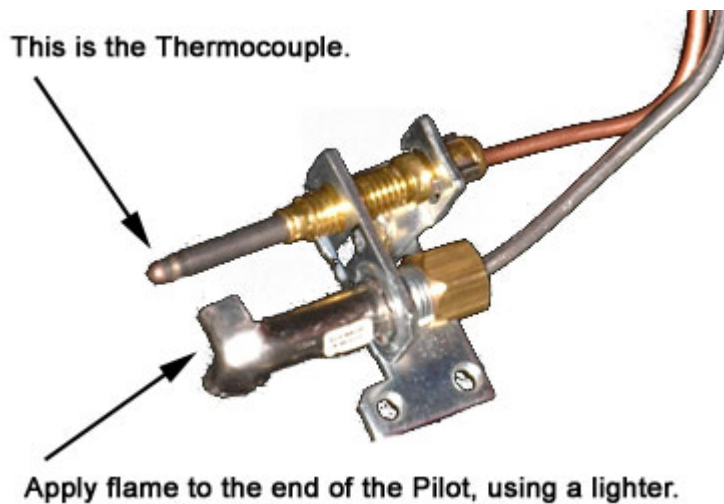

Once you've tested the pilot system to make sure it stays lit, you are ready for the next step.

Step 3

Ramp up some crushed lava rock, starting 2 to 3 inches from the front of the fireplace. Ramp it up to the outside of the burner pan, stopping when you have filled to approximately 1/2 inch from the top edge of the pan. Fill all around the pan (see below) but make sure you do not fill in front of the control tunnel.

Top View of Fireplace Floor and Burner Pan with Crushed Lava Rock Fill

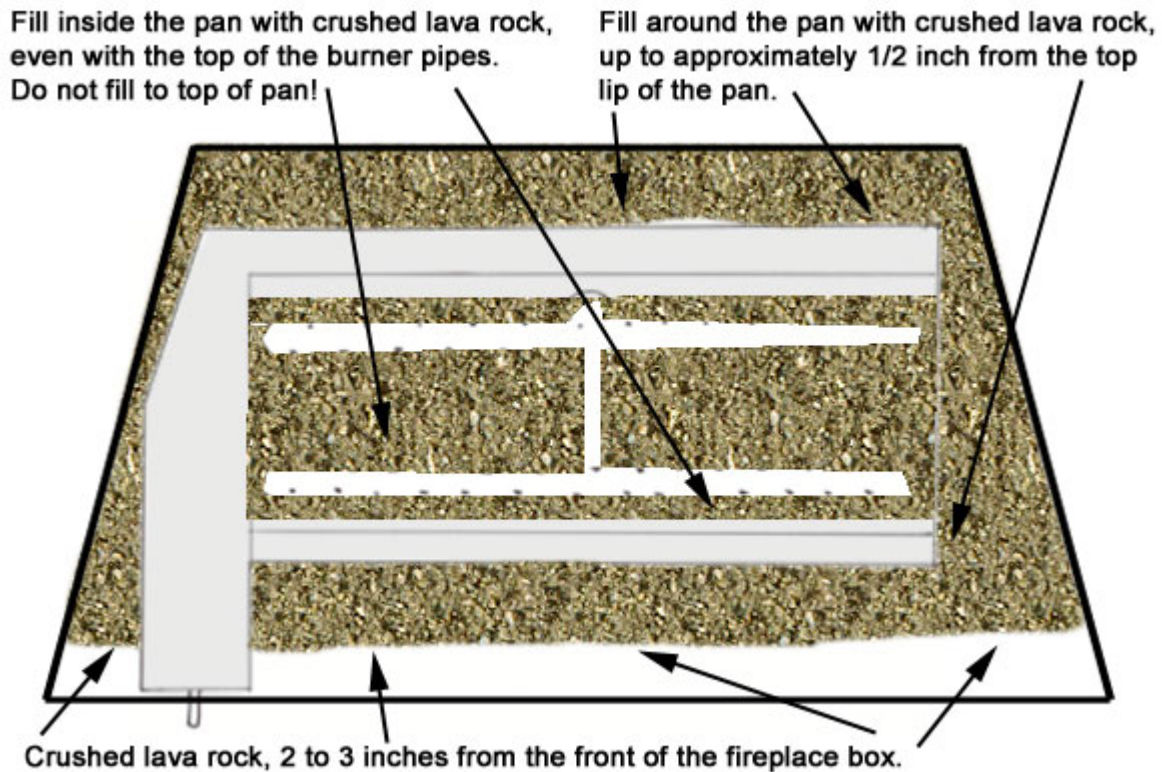

Make note of the location of the rear burner pipe. You will need to position the Thermocouple Assembly directly over the top of the rear burner pipe as you add the Glassel. The Thermocouple Assembly will need to be positioned as shown below.



Step 4

Now pour the Glassel over the top of everything, keeping the Thermocouple Assembly positioned just above the glass and directly over the rear burner pipe, as illustrated.

[Top View of Fireplace Floor with FireGlass Fill](#)

Location of Thermocouple Assembly.

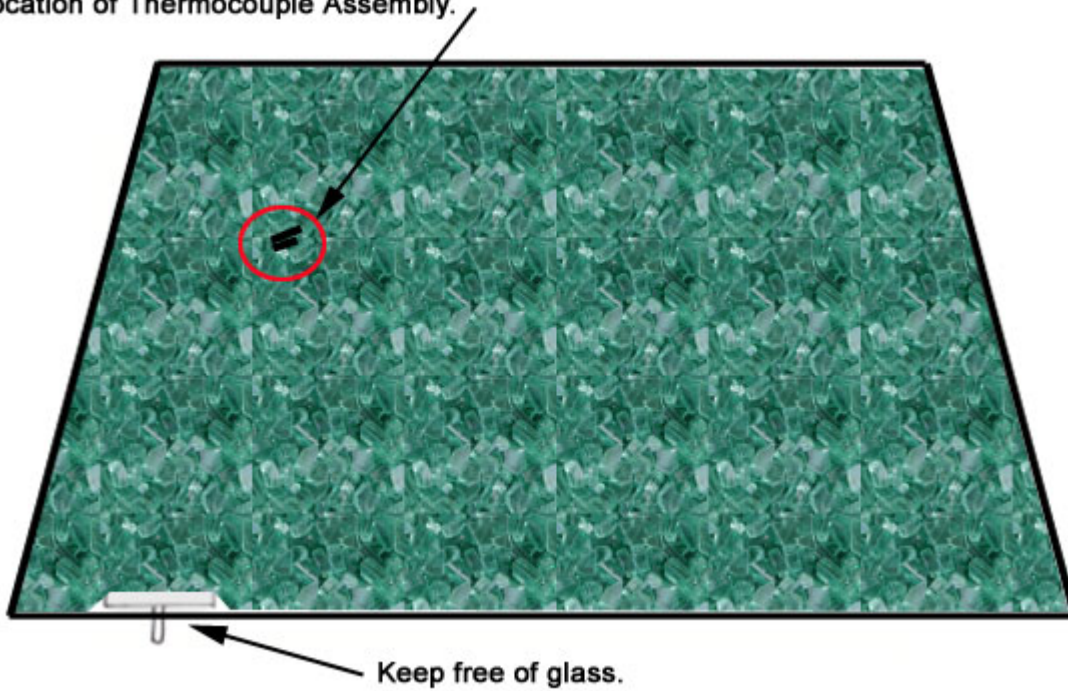

Step 5

! Very Important ! Make sure your damper is fully open before lighting the burner. Always leave the damper fully open and fireplace doors fully open when operating this appliance.

Light the Pilot using the instructions in Step 2. Once the Pilot is lit, turn the knob to the On position. Within a few seconds, the main burner should release gas and you should see a “bed of flame” burning above the glass. If the gas does not ignite quickly enough, your Thermocouple Assembly is probably not centered well enough over the rear burner pipe. First, turn the Pilot Off. Then, making sure the glass and Pilot are both cool to the touch, dig down until you can see the burner pipe. Then realign the Thermocouple assembly and put the glass back in place.

Congratulations! You have completed the installation.

Still have questions? Contact us for support.

Email: ContactUs@ExoticFlames.com
Local Phone: 949-858-5954
Toll Free Phone: 1-877-82-FLAME